

## INSTALLATION PROCEDURE

Note: Refer to LOKRING procedures LP-105 or LP-101 for detailed installation instructions

**STEP 1:** Cut tube to within 5° square. Using 120 grit Aluminum oxide abrasive cloth, sand tube sealing zone in circumferential direction to clean surface and remove scratches. If deep pits or scratches persist, use 60 grit, followed by 120 grit.

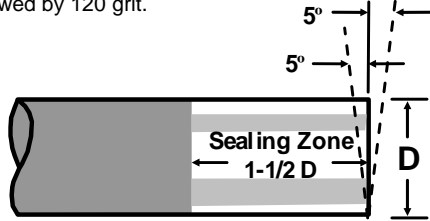

**Step 2:** Using Multipurpose Gage, verify that tube OD is correctly sized, and mark tube ends as shown.

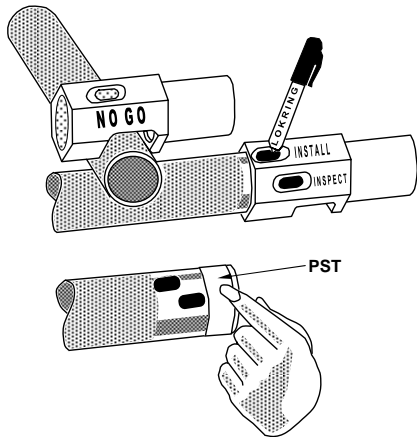

**Special Note:** A thin coat of Loctite® 567 PST (Pipe Sealant with Teflon) may be applied as an aide to seal where tube surface is poor, and is suggested in applications where the tube wall thickness to OD ratio is less than 0.07. The PST should be applied just back from the end of the tube up to the inspect mark; care should be taken to prevent excess PST from entering the system at the tube end.

**STEP 3:** Select and assemble required LOKRING tool. Inspect and cycle tool to assure proper function.

**STEP 4:** Position fitting on "INSTALL" mark, fully engage and actuate tool.

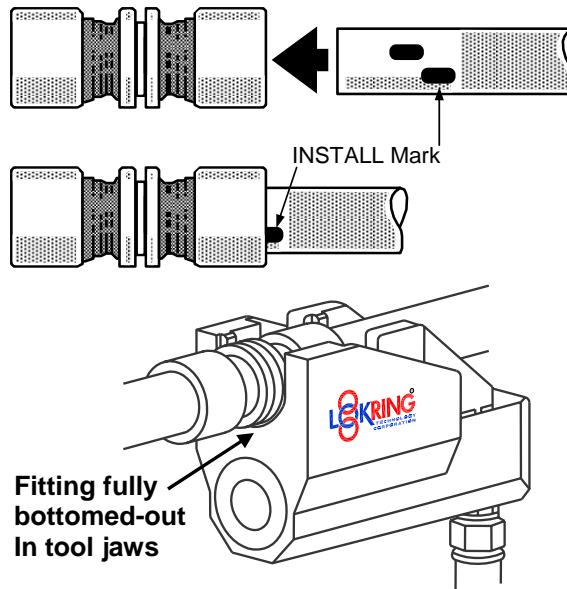

**STEP 5:** Carry out visual checks below to verify successful installation.

Fitting body protrudes from underneath swage ring

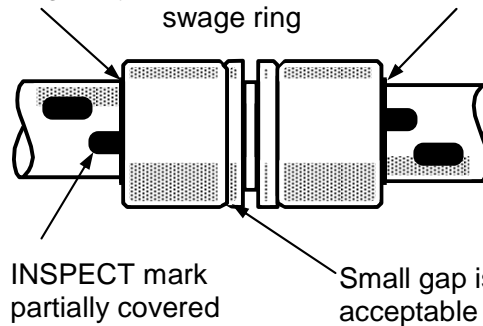

# LOKRING INSTALLER'S Field Installation Guide

For Series SS40 & SS-3000,  
and SS-3300  
316L Stainless Steel  
and  
Series CN-3300  
Copper Nickel  
LOKRING™ Tube Fittings



38376 Apollo Parkway  
Willoughby, OH 44094, USA  
Tel.: (440) 942-0880  
Fax: (440) 942-1186

[www.lokring.com](http://www.lokring.com)

© Copyright 2009 Lokring Technology, LLC  
All rights reserved

8.03E Tri-Fold Handout For Tube Fittings  
(07-02-09)

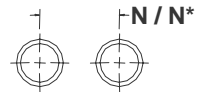
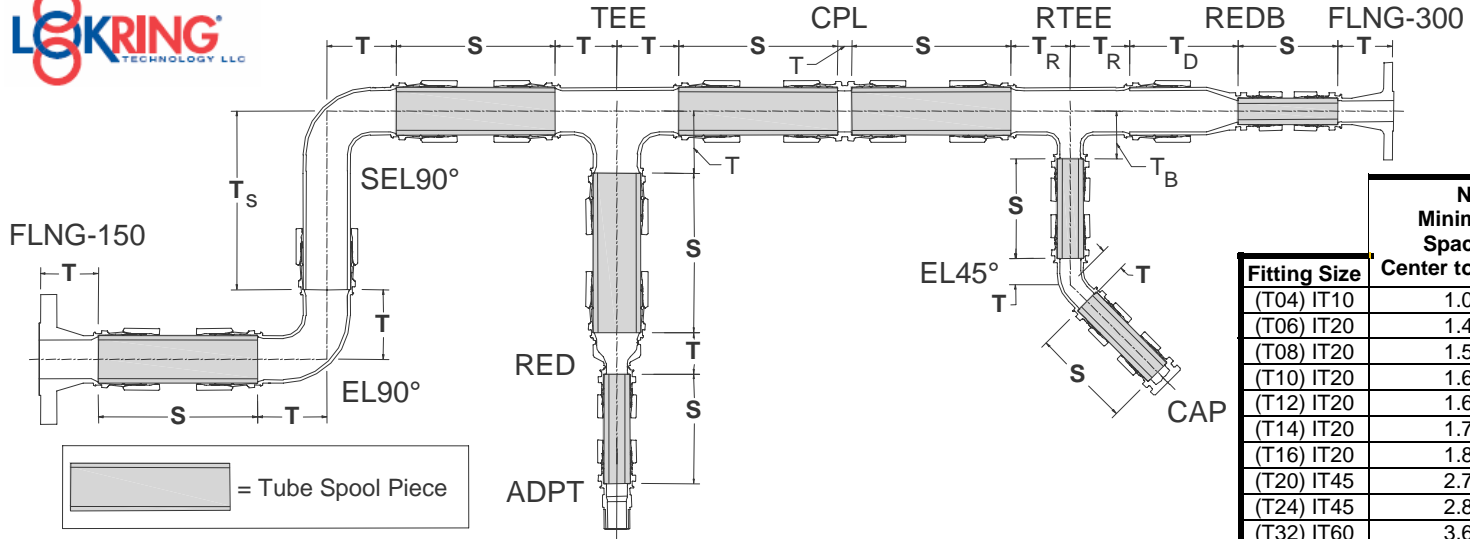

Fitting Size	N Minimum Spacing Center to Center	N* Minimum Spacing Center to Center, with fittings adjacent each other
(T04) IT10	1.09	1.23
(T06) IT20	1.49	1.67
(T08) IT20	1.56	1.74
(T10) IT20	1.62	1.83
(T12) IT20	1.68	1.89
(T14) IT20	1.74	1.91
(T16) IT20	1.81	1.99
(T20) IT45	2.71	2.99
(T24) IT45	2.83	3.14
(T32) IT60	3.63	3.91
(T40) IT60	3.88	4.21

LOKRING Fitting <sup>1,2</sup> (Tube)	LOKTOOL Head	"S" Min <sup>3</sup>	Fitting Take-Out "T" in 1/16" Increments				Reducing Fittings	RTEE T <sub>R</sub>	RTEE T <sub>B</sub>	RED T
			TEE	EL90	CPL	EL45				
<b>CN-3300-XXX-T04 (1/4" Tube)</b>	IT10	2-3/16"	1-1/2"	N/A	1/16"	N/A	<b>3/8"x1/4" (T06xT04)</b>	1-1/8"	1-7/16"	1-3/16"
<b>SS40 &amp; SS-3300-XXX-T04 (1/4" Tube)</b>	IT10	2-3/16"	1-1/2"	N/A	1/16"	N/A	<b>1/2"x1/4" (T08xT04)</b>	N/A	N/A	1"
<b>SS40 &amp; SS-3300-XXX-T06 (3/8" Tube)</b>	IT20	3"	1-1/8"	1-3/16"	N/A	1-3/16"	<b>1/2"x3/8" (T08xT06)</b>	15/16"	1-1/8"	11/16"
<b>SS40 &amp; SS-3300-XXX-T08 (1/2" Tube)</b>	IT20	3-3/16"	15/16"	1"	N/A	1-1/16"	<b>5/8"x1/2" (T10xT08)</b>	1-1/16"	1-1/4"	3/4"
<b>SS40 &amp; SS-3300-XXX-T10 (5/8" Tube)</b>	IT20	3-5/8"	1-1/16"	1-1/16"	N/A	7/8"	<b>3/4"x5/8" (T12xT10)</b>	1-3/16"	1-5/16"	3/4"
<b>SS40 &amp; SS-3300-XXX-T12 (3/4" Tube)</b>	IT20	3-11/16"	1-7/16"	1-7/16"	N/A	1-1/16"	<b>7/8"x3/4" (T14xT12)</b>	1-5/16"	1-3/16"	11/16"
<b>SS-3000-XXX-T14 (7/8" Tube)</b>	IT20	3-1/2"	1-5/16"	1-9/16"	N/A	1-3/16"	<b>1"x7/8" (T16xT14)</b>	1-5/16"	1-5/16"	13/16"
<b>SS-3000-XXX-T16 (1" Tube)</b>	IT20	3-3/4"	1-5/16"	2"	N/A	1-3/8"	<b>1-1/4"x1" (T20xT16)</b>	1-7/8"	2"	7/8"
<b>SS-3000-XXX-T20 (1-1/4" Tube)</b>	IT45	4-11/16"	1-7/8"	1-7/8"	N/A	1-1/4"	<b>1-1/2"x1-1/4" (T24xT20)</b>	2-5/16"	2-5/16"	13/16"
<b>SS-3000-XXX-T24 (1-1/2" Tube)</b>	IT45	4-7/8"	2-5/16"	2-5/16"	N/A	1-7/16"				
<b>SS40-XXX-T32 (2" Tube)</b>	IT60	5-15/16"	3-3/16"	3-11/16"	N/A	2-1/16"				
<b>SS40-XXX-T40 (2-1/2" Tube)</b>	IT60	7-7/8"	3-5/16"	3-13/16"	N/A	2-3/16"				

1. Stainless steel tube to ASTM-A269 or A213 and MIL-P-24691/3 or MIL-T-8606. Refer to LOKRING specification **FS40-T** for qualified Tube specifications and wall thicknesses.  
 2. 70/30 copper-nickel tube per MIL-T-16420 (CN-3300-XXX-T04 Only)  
 3. Minimum cut spool length "S" listed is for reverse installation. Spool lengths may be decreased slightly if one fitting end can be pulled up prior to positioning the second end and the reverse position of the tool is used for the installation.