

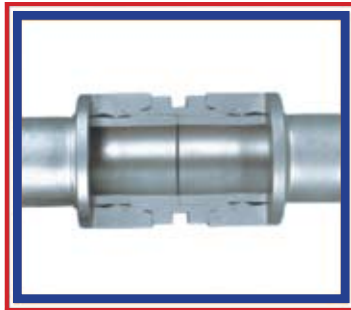

When you need a better connection™



Patented Weld Equivalent Pipe Solutions™

Carbon Steel • Stainless Steel • Copper Nickel • Brass
Fittings for Pipe and Tubing Applications

Advantages of LOKRING Fittings

1. Permanent Connection — No Maintenance and No Repair
 2. No Hot Work — Potential Reduction of OSHA Incidents
 3. Secure Tamper-Proof Fittings — No Threads, Ferrule-Free, No Wrenches
 4. No Purge or Flushing — Zero Contamination Compared to Welding
 5. ANSI/ASME B31.1, B31.3, B31.4, B31.5, B31.8, and B31.9 Qualified
 6. Visual Inspection — Non-Destructive (X-Ray) Testing is Unnecessary
 7. Reliable Weld Equivalent Connection
 8. The Only Mechanically Attached Fitting to Meet API 607 Fire Test
 9. Increased Job Scheduling — Ten Times Faster than Welding
 10. Increased Productivity — Fast and Easy to Install
 11. U-Shaped LOKTOOL™ Allows for Single Plane of Axis During Assembly — Easy Access for Close Space Pipe/Tube Runs
- (Detailed documentation at www.lokring.com)

WHEN and WHERE Should LOKRING Fittings Be Used?

- In confined spaces
- In all weather conditions
- Underwater
- On small or large projects
- On jobs where flammable or explosive conditions may exist
- On jobs where plant downtime is costly and problematic
- On jobs that require working with medical gas systems
- For quick and easy repair/rework
- To free up ASME-certified welders for large bore pipe or pressure vessel welding

Elastic Strain Preload (ESP®) Technology

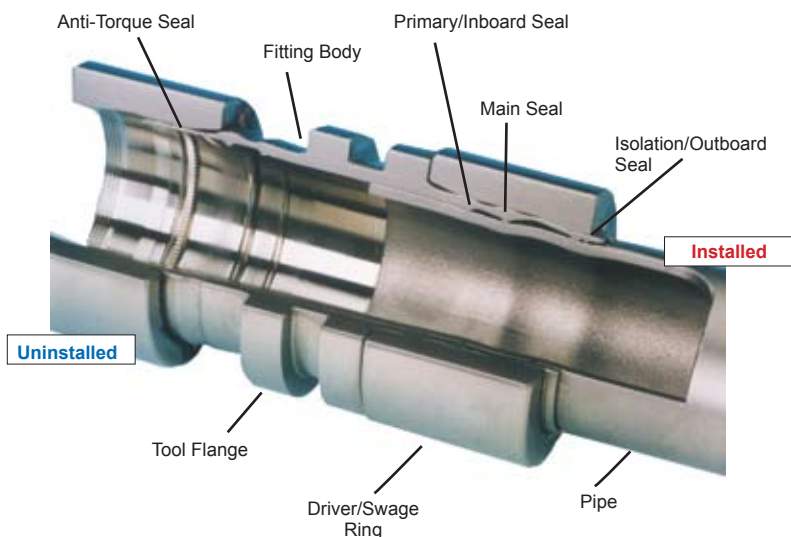

During installation, the axial movement of the LOKRING™ driver over the fitting body swages the body onto the pipe surface, compressing the pipe wall first elastically and then plastically. The pipe wall resists this swaging action, generating high unit compressive loads at the contact points between narrow sealing lands inside the fitting body and the pipe surface.

These contact stresses are sufficiently high to plastically yield the pipe surface under the multiple sealing lands, forming a 360 degree circumferential, permanent, metal-to-metal seal between the pipe and fitting body. The driver, which experiences a small increase in diameter (elastic strain) during installation, exerts an elastic, radial pre-load on the metallic seals for the life of the connection.

LOKRING Meets the Strictest Air Resource Board Qualification (California)

No other connector (flanged or threaded) is capable of passing helium leak testing anywhere close to the level of a LOKRING fitting. LOKRING was independently tested to 2×10^{-11} atmosphere cc/sec Helium leak rate.

In fact, the fitting meets all the criteria of a welded connection, except that no heat is required to make the connection.

The quality of a LOKRING connection has been recognized by the California Air Resources Board (CARB). CARB, through their equipment and process pre-certification program has granted LOKRING pre-certification status through executive order G-096-029-033.

The California Air Resources Board through their evaluation program has given LOKRING equivalent to WELDED status.

NOTE: Please contact LOKRING Customer Services for a copy of our report on Fugitive Emissions.

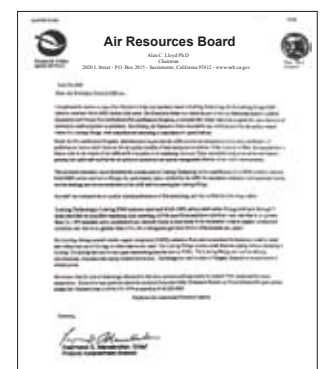

Common Applications

Pulp and Paper



- Hydraulic and Lubrication Oil
- Water: Potable, Hot Shower, Filtered
- Mill and Warm Mill Water
- Steam and Condensate
- Clean and Waste Solvents
- Instrument Air & Control Applications
- Steam Trap Stations

Metal Industries



- Lubricating and Hydraulic Oil
- Breathing Air
- Utility Services
- Instrument Air & Control Applications
- Steam and Condensate
- Coolant and Water

Offshore Production/Refineries



- Utilities, Water, Steam
- Instrument Air
- Condensate & Drain Lines
- Hydrogen Vent/Flare Headers
- Propane, Nitrogen Systems
- Gas Dehydration & Refrigeration
- Clean & Waste Solvents
- Lube Oil

Shipbuilding and Repair



- Fire Hazardous Services
- Lubrication & Hydraulic Oil
- Utility Services
- Steam and Condensate
- Instrument & Control Applications
- NAVSEA, Coast Guard, ABS Approval

Power and Generation



- Steam — Boiler Drain (Non Code)
- CO₂, H₂, N₂ Gases
- Closed Cooling Water
- Condensate — Demineralization Water
- Fuel & Lube Oil
- Heater Vents — Water Systems
- Instrument, Plant and Utility Air

Automotive



- Solvent and Water Based Paints
- Tank Farm Services
- Utility Services
- Process Industry Applications

Chemical Processing Industries



- Distillates & Aromatics • Breathing Air
- Clean and Waste Solvents
- Sealing/Cooling Air • Steam/Condensate
- Hydrocarbons and LPG's
- Polymers and Catalysts • Flare Headers
- VOC (Volatile Organic Compounds)
- Instrument and Control Applications
- Heat Transfer Liquids (i.e. Dowtherm™)

Medical Gas and Vacuum



- Approved NFPA 99 (Para. 5.1.10.7(4)) 2005
- N₂, O₂, Nitrous Oxide Lines
- Vacuum Lines
- Cooling, Utility and Fire Water

Railroad



- Air Brake Systems
- Auxiliary Support Systems
- AAR Unconditional Approval (2003)

Contact your LOKRING Customer Service for specific project application data.

Technical Approvals/Qualifications

ISO 9001:2008 Certified
Lloyd's Register #98/00070 and #10/60002
Canadian Registration Number (CRN)-OA1195
British Ministry of Defence
American Petroleum Institute-API-607 Rev 4 Fire Test
ASTM-F1387 NAVSEA
ANSI/ASME B31.1, B31.3, B31.4, B31.5, B31.8 and B31.9
Association of American Railroads (AAR)
United States Coast Guard
National Fire Protection Association (NFPA 99)
Canadian Standards Association (CSA) Z7396 1-09
California Air Resources Board (CARB)



ASME B31 Qualifications and Testing

Both stainless and carbon steel LOKRING fittings are qualified to the requirements of the ASME B31.1, B31.3, B31.4, B31.5, B31.8 and B31.9 pressure piping codes for pressure and fatigue design and materials of construction.

Extensive mechanical and environmental testing has demonstrated the mechanical and sealing integrity of the LOKRING connection in a wide range of applications and environmental conditions.

Pressure-Torsion Testing:



Figure 1: Pressure-Torsion testing

The 1/2" NPS stainless steel test fitting was subjected to torsional loading high enough to twist the pipe in a spiral without leakage of the joint.

Afterwards, during hydraulic burst testing, the pipe ruptured at 22,000 psi (1497 bar).

Flexural Testing:

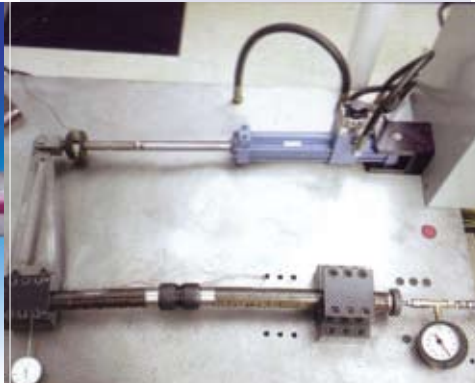

Figure 2: Fatigue testing

The 2" NPS carbon steel coupling above was deflected to 3x the yield strength of the matching pipe without leaking.

The performance of this fitting in severe bending, fatigue, and vibration loads is comparable or superior to a socket weld fitting.

Fire Testing:

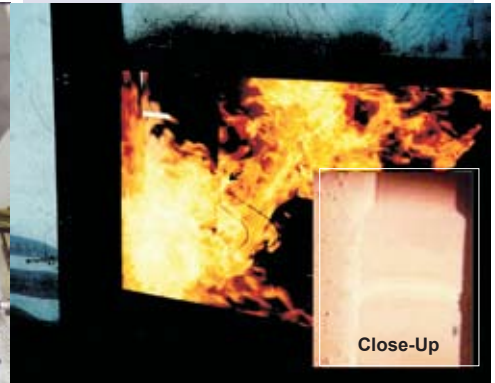

Figure 3: Fire Testing

The metal-to-metal LOKRING seal remains intact when subjected to extreme thermal loads, including fire (above). Stainless and carbon steel LOKRING fittings are qualified to the API-607 Rev 4, fire test standards. Stainless steel fittings and CuNi 90/10 and 70/30 are also qualified to F1387 (U.S. Navy) fire test standards. Both are widely used on volatile and flammable services.

Easy Installation



- 1 Cut and prep pipe/tube.
- 2 Inspect, gauge and mark pipe/tube ends.



- 3 Select and assemble LOKTOOL™.
- 4 Actuate tool to install fitting.



- 5 Remove LOKRING tool head. Inspect completed job.

Twice the Productivity of Welded Pipe

A fitter/helper team can routinely field erect, fit-up, and install 50 to 60 LOKRING fittings in a single shift. This productivity more than doubles the rate at which welded piping systems are typically shop fabricated and field erected.

The increased productivity for a typical job equals \$300.00 savings for every \$1000.00 of the project's cost.

This combination of greater productivity and lower man-hour rates translates to approximately 250% more fittings per hour using LOKRING.

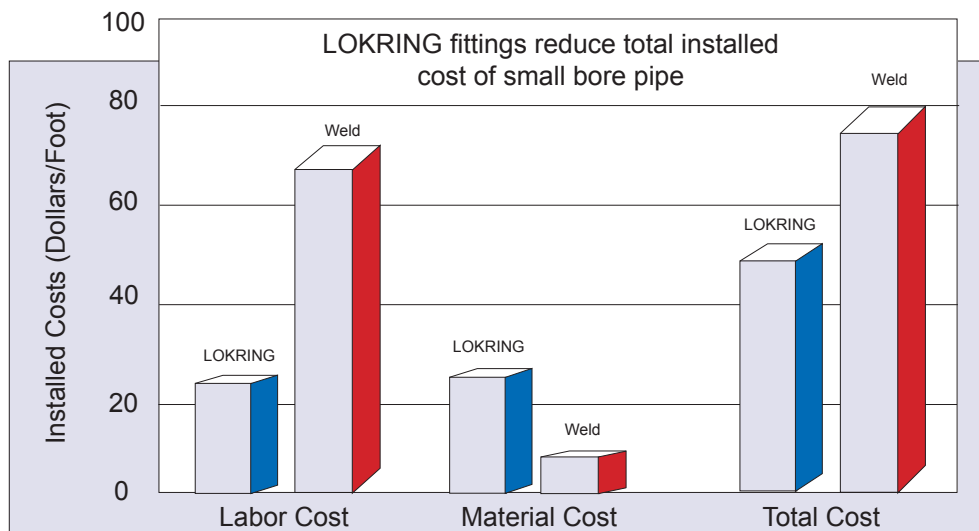

Without the Welding Overhead

By eliminating welding in the unit, many overhead costs relating to safety, personnel, equipment and supplies, inspection, rework, and monitoring can be eliminated or substantially reduced.

Some examples are:

- Obtain fire permit for hot work
- Erect scaffolding and provide ventilation
- "Sniff" area, gas free and weather protect
- Blank flanges and nozzles
- Establish fire watch
- Build fire box or tarps
- Drain, flush and dry lines
- Place equipment, electric cables, and purge line
- Cranes, welders, grinders and small tools
- Weld consumables (purge gas and filler rod)
- Workers' compensation, insurance and benefits
- Weld X-ray or other NDT
- Rework of damaged or misaligned spools
- System soak, flush, or passivation
- HAZMAT disposal
- Maintain and monitor flanges for leakage

In addition, ASME-certified welders are freed up for large bore pipe or pressure vessel welding.



Carbon Steel Pipe Fittings

Qualified matching pipe:

Seamless carbon steel to ASTM A106/A53S/A333
ERW carbon steel to ASTM A53E/A587



Pressure - Temperature Rating

Pipe NPS	Pipe Schedule	Design Pressure*		Design Temperature Degrees in	
		PSI	Bar	°F	°C
1/4"	40/80/160	8,810	607	-20 to 650	-29 to 343
3/8"	40/80/160	7,470	515	-20 to 650	-29 to 343
1/2"	40/80/160	7,000	482	-20 to 650	-29 to 343
3/4"	40/80/160	5,870	404	-20 to 650	-29 to 343
1"	40/80/160	5,300	365	-20 to 650	-29 to 343
1-1/4"	40/80	4,460	308	-20 to 650	-29 to 343
1-1/2"	40/80	3,900	269	-20 to 650	-29 to 343
2"	40/80	3,230	223	-20 to 650	-29 to 343
2-1/2"	40/80	2,970	205	-20 to 650	-29 to 343
3"	40/80	2,470	170	-20 to 650	-29 to 343

*On Schedule 80 matching pipe to ANSI B31.3 at ambient temperature.

See Specification FS-3000 for details.

Do not use carbon steel fittings in "sour" services. LOKRING stainless steel fittings may be a suitable alternative. Contact your local distributor for details.

Stainless Steel Pipe Fittings

Qualified matching pipe:

Stainless steel to ASTM A312

Type 304/304L/316/316L

Carbon steel pipe to ASTM A106/A53S



Pressure - Temperature Rating**

Pipe NPS	Pipe Schedule	Design Pressure*		Design Temperature** Degrees in	
		PSI	Bar	°F	°C
1/4"	10/40/80	6,300	434	-60 to 800	-50 to 425
3/8"	10/40/80	5,200	359	-60 to 800	-50 to 425
1/2"	10/40/80	5,060	348	-60 to 800	-50 to 425
3/4"	10/40/80	4,470	308	-60 to 800	-50 to 425
1"	10/40/80	3,920	270	-60 to 800	-50 to 425
1-1/4"	10/40/80	2,910	201	-60 to 800	-50 to 425
1-1/2"	10/40/80	2,600	179	-60 to 800	-50 to 425
2"	10/40/80	2,300	159	-60 to 800	-50 to 425

*On Schedule 40 matching pipe to ANSI B31.3 at ambient temperature.

See Specification FS40 for details.

** LOKRING welds are done as a standard to ASME B31.3 Normal Services, <750°. For other service applications, consult your local Lokring distributor for details.

Copper Nickel Pipe Fittings

Qualified matching pipe:

Copper nickel 90/10 class 200

per MIL-T-16420 250PSI

Copper per MIL-T-24107

to 200 PSI, .065 wall

Copper nickel 70/30 class 200

and 700 per MIL-T-16420



Pressure - Temperature Rating

Pipe NPS	O.D.	Design Pressure*		Design Pressure*		Design Temperature Degrees in	
		PSI	Bar	PSI	Bar	°F	°C
—	0.250"	*	*	*	*	-60 to 425	-51 to 218
—	0.500"	—	—	700	48	-60 to 425	-51 to 218
1/4"	0.540"	250	17	700	48	-60 to 425	-51 to 218
3/8"	0.675"	250	17	700	48	-60 to 425	-51 to 218
1/2"	0.840"	250	17	700	48	-60 to 425	-51 to 218
3/4"	1.050"	250	17	700	48	-60 to 425	-51 to 218
1"	1.315"	250	17	700	48	-60 to 425	-51 to 218
1-1/4"	1.660"	250	17	700	48	-60 to 425	-51 to 218
1-1/2"	1.900"	250	17	700	48	-60 to 425	-51 to 218
2"	2.375"	250	17	700	48	-60 to 425	-51 to 218

* 1/4 O.D. CN-3300 - rating is 3300 PSI

Pressure - Temperature Rating**

Tube O.D.	Wall min. / max.	Design Pressure* min wall / max wall		Design Temperature** Degrees in	
		PSI	Bar	°F	°C
1/4"	0.035/0.065"	5100/9050	352/624	-60 to 800	-50 to 425
3/8"	0.035/0.065"	3300/5650	228/390	-60 to 800	-50 to 425
1/2"	0.035/0.065"	2600/4270	179/294	-60 to 800	-50 to 425
5/8"	0.035/0.065"	2100/3750	145/259	-60 to 800	-50 to 425
3/4"	0.035/0.065"	1700/3300	117/228	-60 to 800	-50 to 425
7/8"	0.065"	2800	193	-60 to 800	-50 to 425
1"	0.065/0.083"	2400/3100	165/214	-60 to 800	-50 to 425
1-1/4"	0.065/0.109"	1900/3300	131/228	-60 to 800	-50 to 425
1-1/2"	0.065/0.120"	1600/3000	110/207	-60 to 800	-50 to 425
2"	0.065/0.083"	1100/1500	76/103	-60 to 800	-50 to 425
2-1/2"	0.065/0.083"	900/1200	62/83	-60 to 800	-50 to 425

*At ambient temperature - See specification FS40-T for details.
 On min/max wall, matching tubing to ANSI B31.3 at Ambient temperatures. See specifications FS540-T.
 ** LOKRING welds are done as a standard to ASME B31.3 Normal Services. <750°. For other service applications, consult your local LOKRING distributor for details.

Stainless Steel Tube Fittings

Qualified matching tube:
 Seamless steel to ASTM A269 or A213
 Many fitting shapes available —
 Unions, Male Elbows, Union Tees, etc.



Pressure - Temperature Rating

Nominal Fitting Size (TXX)	Tube O.D.	Qualified Wall Thickness K		Qualified Wall Thickness L		Qualified Wall Thickness M	
		Wall	Pressure	Wall	Pressure	Wall	Pressure
3/8"	0.500	0.049	1946	0.035	1341	0.025	982
1/2"	0.625	0.049	1534	0.040	1242	0.028	850
5/8"	0.750	0.049	1266	0.042	1086	—	—
3/4"	0.875	0.065	1466	0.045	1002	0.032	701
1"	1.125	0.065	1126	0.050	850	0.035	580
1-1/4"	1.375	0.065	914	0.055	755	0.042	582
1-1/2"	1.625	0.072	850	0.060	702	0.049	569
2"	2.125	0.083	747	0.070	625	0.058	514

Exceeds Required Temperature of 1000°F
 Pressure rating should be derated at elevated temperature. Fittings meet 1000°F integrity test.
 See specification FS-BR for details.
 Design temperature -452°F to 400°F (-269°C to 204°C)

Brass Tube Fittings

Qualified matching tube:
 ASTM B88 drawn types K,L,M
 ASTM B819 types K,L



Specials



Medical Gas Fittings

Many options available,
 consult your local distributor for details.



Railroad Fittings

See our newly released
 extended flanges on our website:
www.LOKRING.com

Many standard and special fitting configurations other than those shown above are available.

Selection Tool Kits



Tool kits are material specific and are available for Brass, Copper, Copper Nickel, Carbon and Stainless Steel pipe/tubing in sizes ranging from 1/4" OD through 3" NPS.

A tool kit consists of the appropriate tool head with replaceable insert(s) for multiple sizes (except non-replaceable inserts for 3" NPS), marking gauge(s) and a sturdy carrying case.

Installation instructions and kit inventory sheets accompany the tool kit.

The hydraulic tool requires a hose and pump (hand, electric or air hydraulic) to complete the installation kit.

**To order Fittings or Tool Kits refer to our website
www.lokring.com or contact your local distributor.**

Headquarters
38376 Apollo Parkway
Willoughby, Ohio 44094
Phone: 440-942-0880
Toll Free: 800-876-2323
Fax: 440-942-1186

www.lokring.com

All the above information including illustrations is believed to be reliable. Users, however, should independently evaluate the suitability of each product for their application. LOKRING's only obligation are those in the standard terms and conditions of sale for this product and in no case will LOKRING be liable for any incidental, indirect, or consequential damages arising from the sale, resale, use, or misuse of the product.



Ideal for small pipe/tube fittings, handheld portable LOKTOOL kit has a 360 degree swivel head.



Many tool kits are versatile by offering multiple tool inserts and gauges in one case.



Various hydraulic power options are shown here with the hose and the IT20 LOKTOOL.



Sampling of tool heads available, they can be ordered with single or multiple size inserts.