

**APPENDIX A:
Envelope Dimensions and Space requirements**

CN-700 Series Copper Nickel Pipe and Tube Fittings

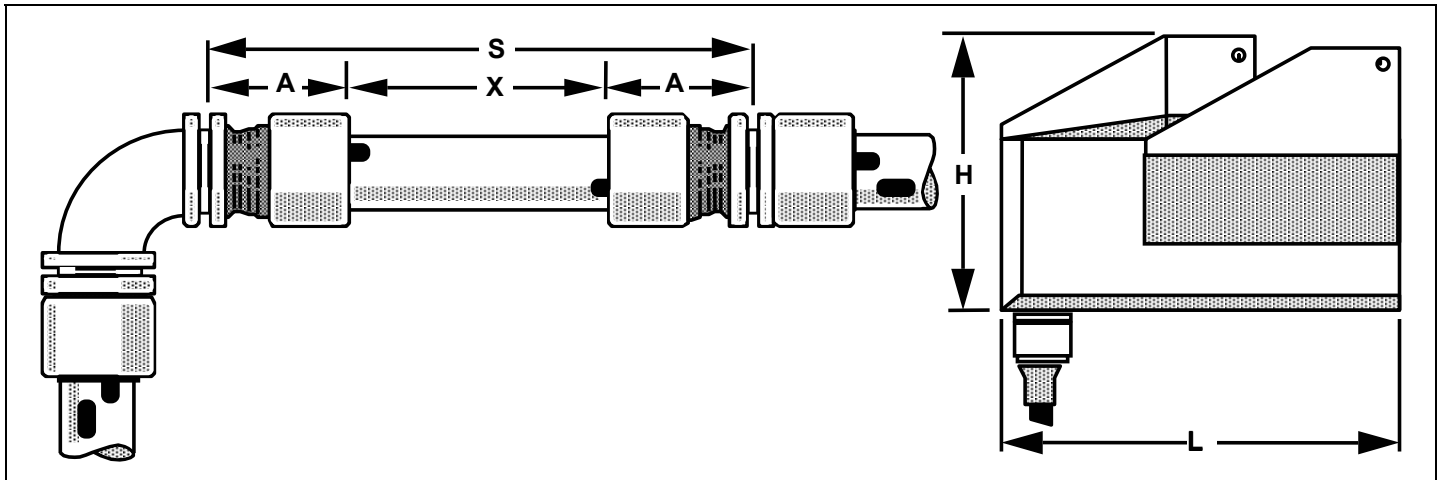

Dimensions in Inches			S	X	A	L	H
Fitting Size	Pipe Or Tube OD	LOKTOOL Size	Minimum Spool Length	Minimum Spacing Between Fittings	Pre-Installed Insertion Depth, Nominal	Tool Length	Tool Height
1/2" (T08)	0.500	IT10	3.14	0.57	1.29	5.01	3.21
1/2" (T08)	0.500	IT20	3.14	0.57	1.29	5.01	3.21
1/4" (P04)	0.540	IT10	3.14	0.57	1.29	5.01	3.21
1/4" (P04)	0.540	IT20	3.14	0.57	1.29	5.01	3.21
3/8" (P06)	0.675	IT20	3.36	0.56	1.40	5.01	3.21
1/2" (P08)	0.840	IT20	3.79	0.58	1.61	5.01	3.21
3/4" (P12)	1.050	IT30	4.31	0.59	1.86	6.46	3.98
3/4" (P12)	1.050	IT45	4.54	0.82	1.86	6.38	4.91
1" (P16)	1.315	IT45	4.94	0.62	2.16	6.38	4.91
1" (P16)	1.315	IT50	4.94	0.62	2.16	7.29	5.33
1-1/4" (P20)	1.660	IT45	5.82	0.63	2.59	6.38	4.91
1-1/4" (P20)	1.660	IT50	5.83	0.64	2.59	7.29	5.33
1-1/2" (P24)	1.900	IT60	6.81	0.85	2.98	8.59	5.84
2" (P32)	2.375	IT60	7.88	1.34	3.27	8.59	5.84

Note: Spool lengths are for reverse operation, except where noted. Spool lengths may be decreased slightly if one fitting end can be pulled up prior to positioning the second end and the reverse position of the tool is used for the installation.

APPENDIX A:
Envelope Dimensions and Space requirements

CN-700 Series Copper Nickel Pipe and Tube Fittings

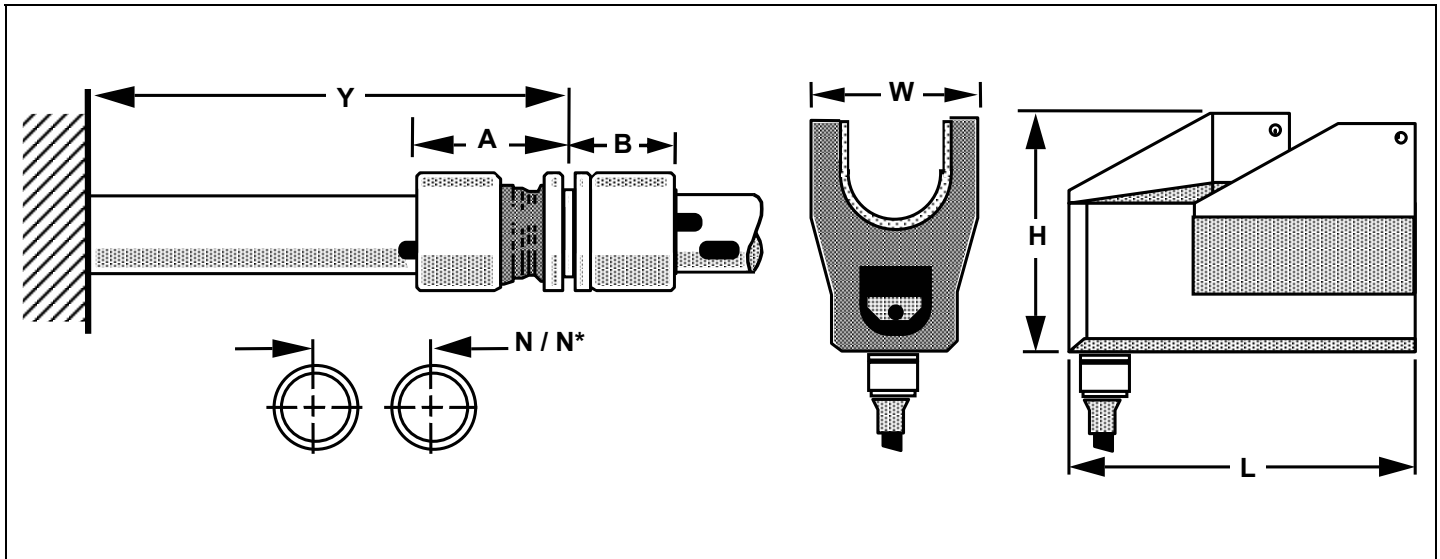

Dimensions in Inches			W	N	N*	Y	B
Fitting Size	Pipe Or Tube OD	LOKTOOL Size	Tool Width	Minimum Spacing Center to Center	Minimum Spacing Center to Center, with fittings adjacent each other	Extension from Bulkhead, Minimum	Insertion Depth Installed, Nominal
1/2" (T08)	0.500	IT10	1.67	1.21	1.38	1.85	0.95
1/2" (T08)	0.500	IT20	2.36	1.56	1.73	1.85	0.95
1/4" (P04)	0.540	IT10	1.67	1.23	1.38	1.85	0.95
1/4" (P04)	0.540	IT20	2.36	1.58	1.73	1.85	0.95
3/8" (P06)	0.675	IT20	2.36	1.64	1.83	1.96	1.04
1/2" (P08)	0.840	IT20	2.36	1.73	1.94	2.18	1.18
3/4" (P12)	1.050	IT30	2.66	1.98	2.20	2.45	1.36
3/4" (P12)	1.050	IT45	3.91	2.61	2.83	2.68	1.36
1" (P16)	1.315	IT45	3.91	2.74	2.98	2.78	1.57
1" (P16)	1.315	IT50	4.21	2.89	3.13	2.78	1.57
1-1/4" (P20)	1.660	IT45	3.91	2.91	3.13	3.23	1.88
1-1/4" (P20)	1.660	IT50	4.21	3.06	3.28	3.24	1.88
1-1/2" (P24)	1.900	IT60	5.01	3.58	3.84	3.83	2.16
2" (P32)	2.375	IT60	5.01	3.82	4.15	4.61	2.37

Note: "Y" assumes that the tool is operated in Reverse Mode.