

**APPENDIX A:
Envelope Dimensions and Space requirements**

SS40 and SS-3300 Series Stainless Steel Pipe Fittings

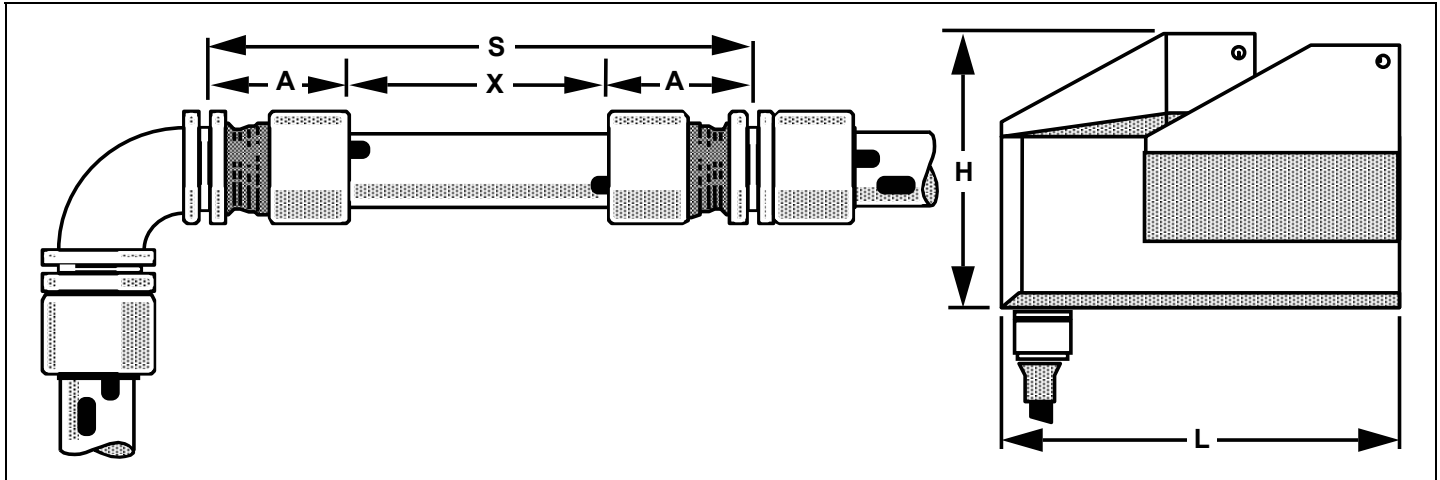

Dimensions in Inches			S	X	A	L	H
Fitting Size	Pipe Or Tube OD	LOKTOOL Size	Minimum Spool Length	Minimum Spacing Between Fittings	Pre-Installed Insertion Depth, Nominal	Tool Length	Tool Height
1/4" (P04)	0.540	IT20	3.47	0.59	1.44	5.00	3.20
3/8" (P06)	0.675	IT30	3.84	0.65	1.60	6.45	3.97
3/8" (P06)	0.675	IT45	3.84	0.65	1.60	6.38	4.91
3/8" (P06)	0.675	IT50	3.84	0.65	1.60	7.29	5.33
1/2" (P08)	0.840	IT30	4.09	0.65	1.72	6.45	3.97
1/2" P(08)	0.840	IT45	4.09	0.65	1.72	6.38	4.91
1/2" P(08)	0.840	IT50	4.09	0.65	1.72	7.29	5.33
3/4" (P12)	1.050	IT30	4.52	0.65	1.94	6.45	3.97
3/4" (P12)	1.050	IT45	4.52	0.65	1.94	6.38	4.91
3/4" (P12)	1.050	IT50	4.52	0.65	1.94	7.29	5.33
1" (P16)	1.315	IT45	5.21	0.82	2.20	6.38	4.91
1" (P16)	1.315	IT50	5.10	0.70	2.20	7.29	5.33
1" (P16)	1.315	IT60	5.18	0.79	2.20	8.59	5.84
1-1/4" (P20)	1.660	IT50	5.83	0.81	2.51	7.29	5.33
1-1/4" (P20)	1.660	IT60	6.07	1.04	2.51	8.59	5.84
1-1/2" (P24)	1.900	IT50	6.19	0.59	2.80	7.29	5.33
1-1/2" (P24)	1.900	IT60	6.45	0.85	2.80	8.59	5.84
2" (P32)	2.375	IT50	6.93	0.79	3.07	7.29	5.33
2" (P32)	2.375	IT60	6.91	0.77	3.07	8.59	5.84

Note: Spool lengths are for reverse operation, except where noted. Spool lengths may be decreased slightly if one fitting end can be pulled up prior to positioning the second end and the reverse position of the tool is used for the installation.

**APPENDIX A:
Envelope Dimensions and Space requirements**

SS40 and SS-3300 Series Stainless Steel Pipe Fittings

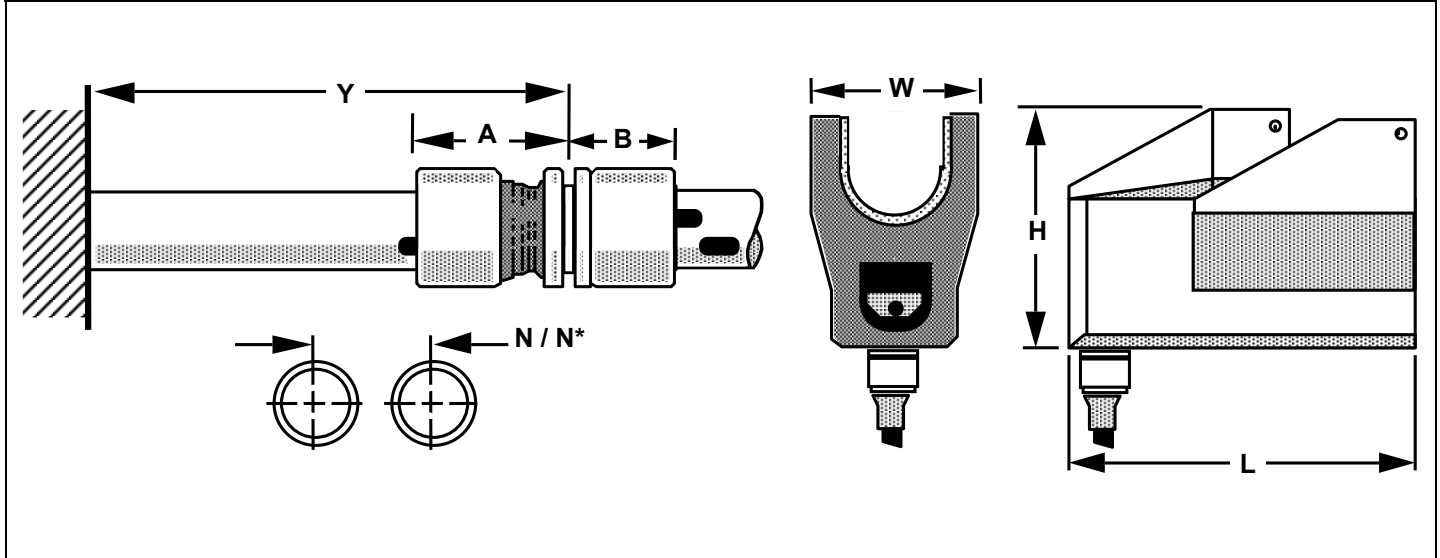

Dimensions in Inches			W	N	N*	Y	B
Fitting Size	Pipe Or Tube OD	LOKTOOL Size	Tool Width	Minimum Spacing Center to Center	Minimum Spacing Center to Center, with fittings adjacent each other	Extension from Bulkhead, Minimum	Insertion Depth Installed, Nominal
1/4" (P04)	0.540	IT20	2.36	1.58	1.83	2.03	1.05
3/8" (P06)	0.675	IT30	2.66	1.80	2.08	2.24	1.18
3/8" (P06)	0.675	IT45	3.91	2.43	2.70	2.24	1.18
3/8" (P06)	0.675	IT50	4.21	2.58	2.85	2.24	1.18
1/2" (P08)	0.840	IT30	2.66	1.88	2.19	2.37	1.29
1/2" P(08)	0.840	IT45	3.91	2.51	2.81	2.37	1.29
1/2" P(08)	0.840	IT50	4.21	2.66	2.96	2.37	1.29
3/4" (P12)	1.050	IT30	2.66	1.99	2.27	2.58	1.44
3/4" (P12)	1.050	IT45	3.91	2.61	2.90	2.58	1.44
3/4" (P12)	1.050	IT50	4.21	2.76	3.05	2.58	1.44
1" (P16)	1.315	IT45	3.91	2.75	3.06	3.02	1.66
1" (P16)	1.315	IT50	4.21	2.90	3.21	2.90	1.66
1" (P16)	1.315	IT60	5.01	3.30	3.61	2.98	1.66
1-1/4" (P20)	1.660	IT50	4.21	3.07	3.41	3.32	1.90
1-1/4" (P20)	1.660	IT60	5.01	3.47	3.81	3.56	1.90
1-1/2" (P24)	1.900	IT50	4.21	3.19	3.52	3.39	2.05
1-1/2" (P24)	1.900	IT60	5.01	3.59	3.92	3.65	2.05
2" (P32)	2.375	IT50	4.21	3.43	3.79	3.86	2.41
2" (P32)	2.375	IT60	5.01	3.83	4.19	3.84	2.41

Note: "Y" assumes that the tool is operated in Reverse Mode.

**APPENDIX A:
Envelope Dimensions and Space requirements**

MAS-3000, SS40, SS-3300 Series Pipe Fittings ITK100 3 inch Tooling

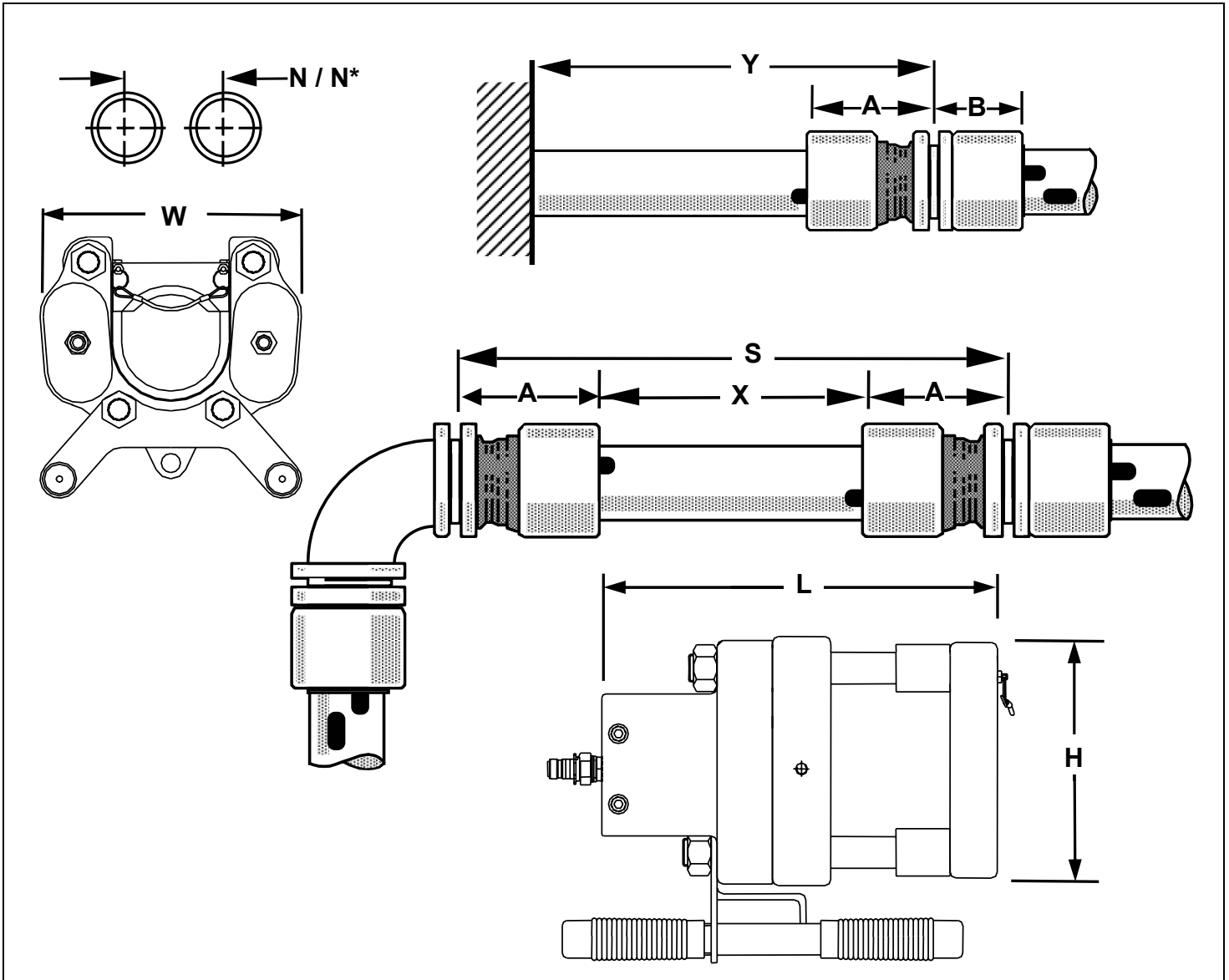

Dimensions in Inches	L	W	H	N	N*	Y	S	X	B	A
Fitting Size	Tool Length	Tool Width	Tool Height	Minimum Spacing Center to Center	Minimum Spacing Center to Center, with fittings adjacent each other	Extension from Bulkhead, Minimum	Minimum Spool Length	Minimum Spacing Between Fittings	Installed Insertion Depth, Nominal	Pre-Installed Insertion Depth, Nominal
MAS-3000	12.52	10.18	7.89	6.98	7.39	5.54	9.83	1.25	2.99	4.29
SS40	12.52	10.18	7.89	6.98	7.47	5.97	10.68	1.25	3.41	4.71

Note: Spool lengths are for reverse operation, except where noted. Spool lengths may be decreased slightly if one fitting end can be pulled up prior to positioning the second end and the reverse position of the tool is used for the installation.
 "Y" assumes that the tool is operated in Reverse Mode.