

**APPENDIX D:**  
**Envelope Dimensions and Space requirements**

**BR Series LOKRING Medical Gas Fittings for copper tubing**

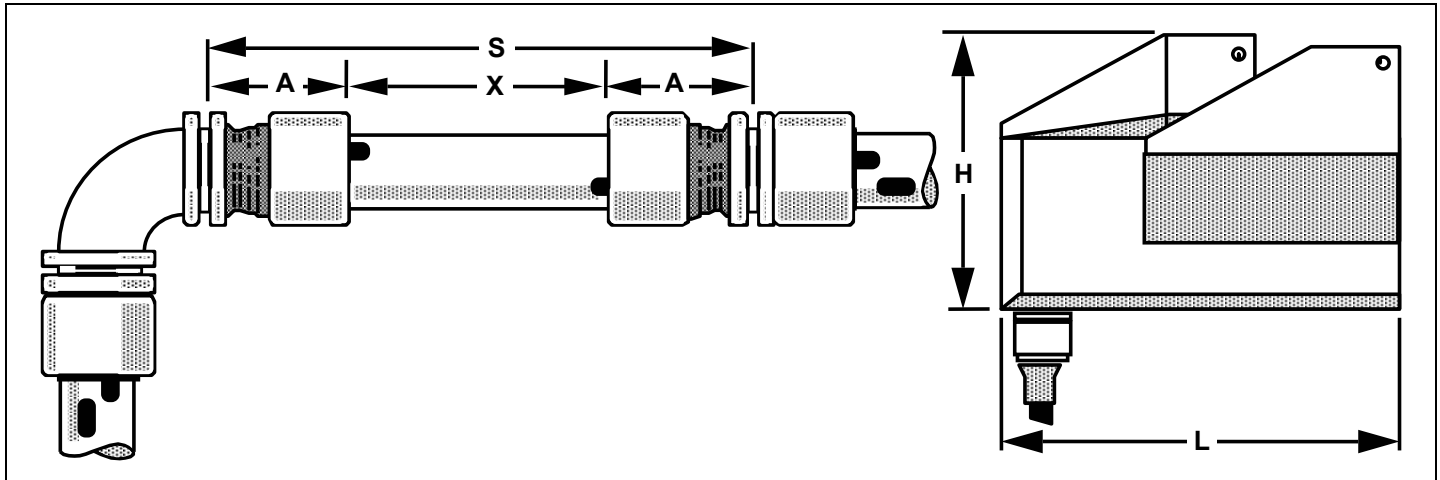

Dimensions in Inches			S	X	A	L	H
Fitting Size	Tube OD	LOKTOOL Size	Minimum Spool Length	Minimum Spacing Between Fittings	Pre-Installed Insertion Depth, Nominal	Tool Length	Tool Height
1/2" (T08)	0.625	IT20	3.06	0.57	1.25	5.00	3.20
5/8" (T10)	0.750	IT20	3.43	0.59	1.42	5.00	3.20
3/4" (T12)	0.875	IT20	3.67	0.54	1.57	5.00	3.20
1" (T16)	1.125	IT45	4.74	0.65	2.05	6.38	4.91
1-1/4" (T20)	1.375	IT45	5.46	0.82	2.32	6.38	4.91
1-1/2" (T24)	1.625	IT45	6.02	0.72	2.65	6.38	4.91
1-1/2" (T24)	1.625	IT50	6.11	0.81	2.65	7.29	5.33
2" (T32)	2.125	IT50	7.69	0.79	3.45	7.29	5.33

**Note:** Spool lengths are for reverse operation, except where noted. Spool lengths may be decreased slightly if one fitting end can be pulled up prior to positioning the second end and the reverse position of the tool is used for the installation.

**APPENDIX D:  
 Envelope Dimensions and Space requirements**

**BR Series LOKRING Medical Gas Fittings for copper tubing**

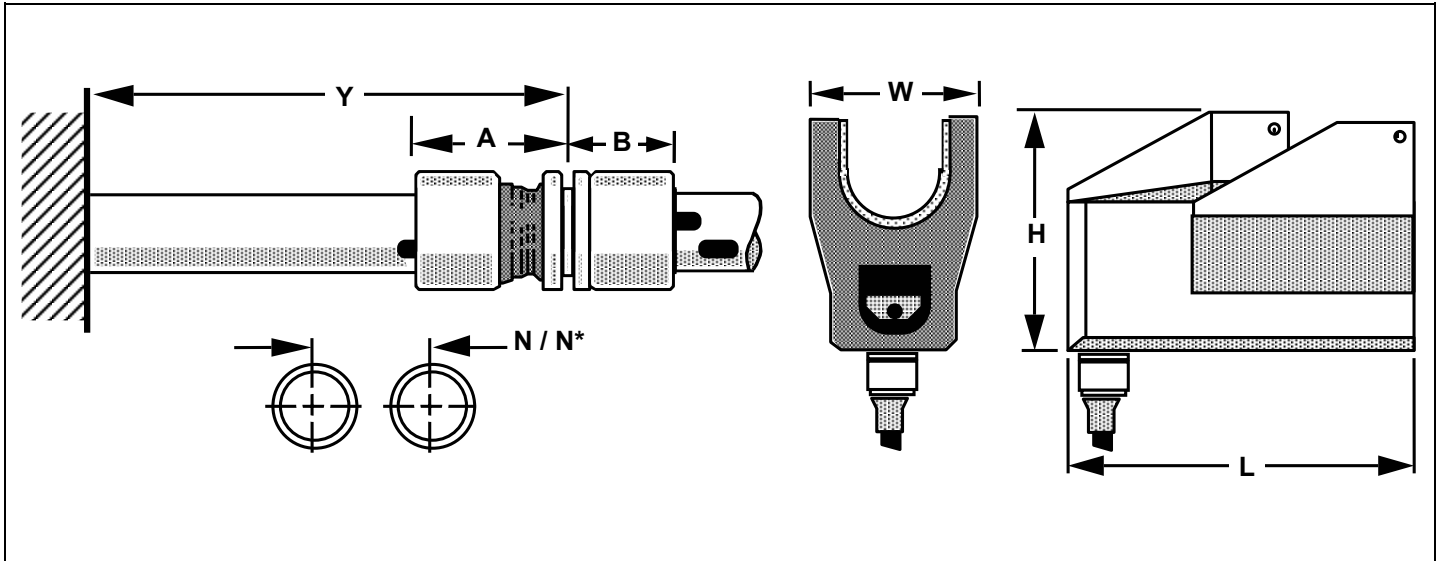

Dimensions in Inches			W	N	N*	Y	B
Fitting Size	Tube OD	LOKTOOL Size	Tool Width	Minimum Spacing Center to Center	Minimum Spacing Center to Center, with fittings adjacent each other	Extension from Bulkhead, Minimum	Insertion Depth Installed, Nominal
1/2" (T08)	0.625	IT20	2.36	1.62	1.76	1.82	0.98
5/8" (T10)	0.750	IT20	2.36	1.68	1.82	2.01	1.10
3/4" (T12)	0.875	IT20	2.36	1.74	1.91	2.10	1.20
1" (T16)	1.125	IT45	3.91	2.64	2.85	2.69	1.56
1-1/4" (T20)	1.375	IT45	3.91	2.77	3.01	3.14	1.78
1-1/2" (T24)	1.625	IT45	3.91	2.89	3.19	3.37	2.03
1-1/2" (T24)	1.625	IT50	4.21	3.04	3.34	3.46	2.03
2" (T32)	2.125	IT50	4.21	3.29	3.67	4.24	2.64

**Note:** "Y" assumes that the tool is operated in Reverse Mode.